

RB-1000

12VDC - (13-18VDC / 100A)

Binding post connector

For Input & Output

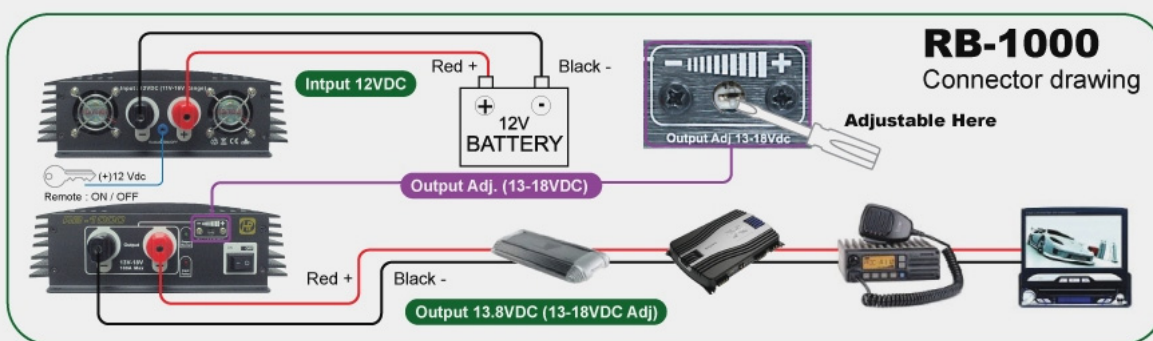

Specifications :

Model	RB-1000
Input Voltage Range	12VDC (10V DC – 15V DC)
Output Voltage	13.8VDC (13-18V Adjustable)
Max. Output Current	100A
Continuous Current	80A
No Load Input Current	500mA
Line Regulation	≤ 0.1%
Load Regulation	0.02%
Output Ripple Noise	100mV (rms)
Efficiency	Over 80%
Indicators	Power on LED
Inputs connection type	Binding Post
Output connection type	Binding Post
Input Fuse Type Car blade	30A x 4 build in PCB
Dimensions L x W x H (mm)	190 x 400 x 70
Weight (kg)	4
Cooling System	Thermally Control Fan

Product Features :

- Special design and decorous car aluminum heat sink housing
- Less heat dissipation without over-heating problem
- Switching-mode technology (25KHz)
- High efficiency over (80%)
- Good load and line regulations
- Wide input voltage range
- Forced air cooling
- Power on / off switch
- Input : 12VDC (10VDC~15VDC)
- Output : 13.8VDC (13VDC~18VDC Adj.)

